

Filter Receiver - TL



Appcon top loading filter receivers are custom designed to accommodate a wide variety of process configurations and are the perfect fit for pneumatic conveying applications.



7261TLFR12A

2407TLFR08B

Available in a variety of finishes including:

- Food Grade
- USDA-3A Dairy
- Advanced Food Grade
- Plastics
- Chemicals
- Nutraceuticals
- Heavy Duty Industrial

Other Options:

- Support frames
- Surge hoppers
- Vibratory/Pneumatic hopper agitation
- Integrated load cell kits
- System controls for complete process automation
- Custom configurations to fit your process

Pneumatic Conveying Options:

- Vacuum
- Pressure
- Dilute phase
- Semi-dense phase
- Dense phase

Discharge Configurations:

- Integrated hopper
- Full diameter flange
- Butterfly valve
- Airlock for continuous discharge



Filter Receiver – TL

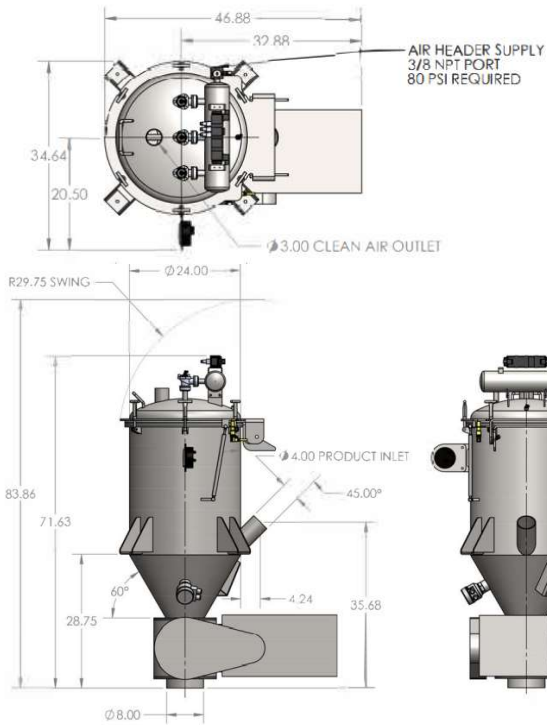

2407TLFR08A

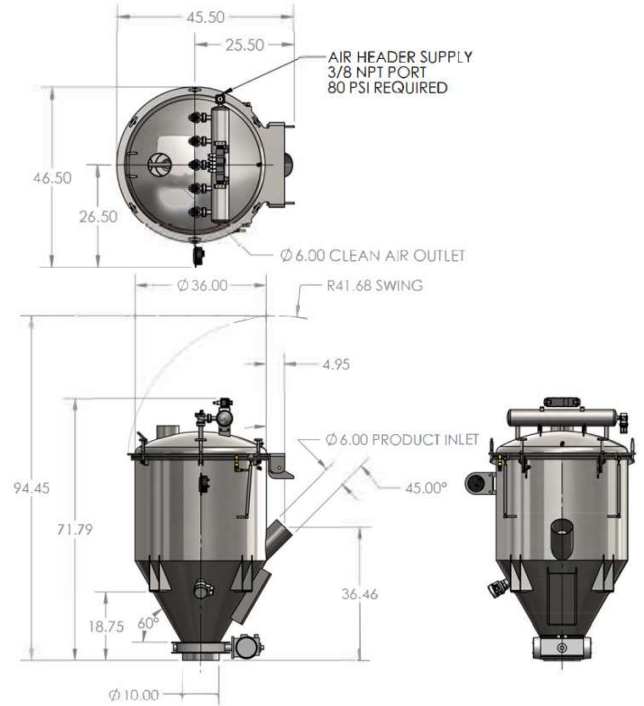

3619TLFR10B

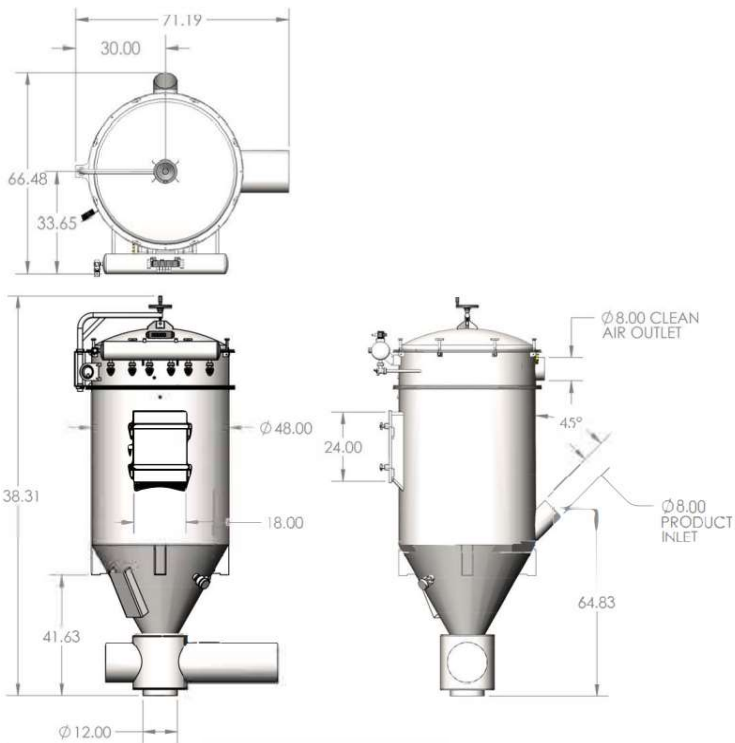

4828TLFR12A

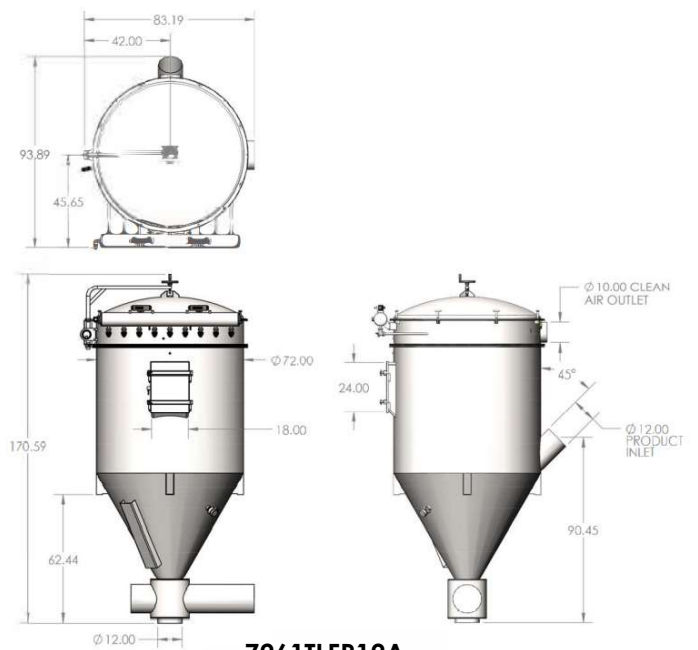

7261TLFR12A